



SUPPLY AND DELIVERY OF FIRE FIGHTING UNIFORM FOR FIRE PERSONNEL FOR A PERIOD OF THREE (3) YEARS

NOTICE: **068 OF 2026**

BID NO: **8/2/RNM0647**

NAME OF THE BIDDER

BID AMOUNT R _____

PUBLIC SAFETY
FIRE AND DISASTER SECTION
P.O. BOX 5
PORT SHEPSTONE
4240

JUNE 2026

TABLE OF CONTENTS

	Page number
1. Bid Advert	3-4
2. Standard forms	5-7
3. Evaluation Criteria	8
4. General conditions of contract	9-22
5. Attachments:	
6.1. RNM /MBD 3.2. Pricing Schedule(Non-Firm Prices)	23-46
6.2. RNM /MBD 4. Declaration of Interest	47-49
6.3. RNM /MBD 6.1.Preference Points Claim Form In Terms Of The Preferential Procurement Regulations 2022	50-53
6.5 RNM /MBD 8 Declaration past SCM practices	54-55
6.6. RNM /MBD 9 Certificate of Independent Bid Determination	56-58

**MUNICIPAL NOTICE: 068 of 2026
BID NO: 8/2/RNM0647**

SUPPLY AND DELIVERY OF FIRE FIGHTING UNIFORM FOR FIRE PERSONNEL FOR A PERIOD OF THREE (3) YEARS

The Ray Nkonyeni Municipality hereby invites bids for the Supply and Delivery of Fire Fighting Uniform for Fire Personnel for a three-year period.

Bid documents can be downloaded for free from e-tenders portal <https://etenders.treasury.gov.za> and Ray Nkonyeni Municipality website www.rnm.gov.za from Friday, 5 June 2026

Bidders to submit one (01) copy of the bid document together with the original bid document, bidders that fail to submit copy will be disqualified. Fully completed Bid documents must be submitted in a sealed envelope, clearly marked "8/2/RNM0647 Supply and Delivery of Fire Fighting Uniform for Fire Personnel for a three year period and must be deposited in the Bid box at the Municipal offices at 10 Connor Street, Port Shepstone, no later than 12h00 on 6 July 2026 after which all Bids will be opened in public.

Enquiries can be directed to Mr Ramchander on 0616612992, Pravesh.Ramchander@rnm.gov.za

SPECIFIC GOALS	POINTS
an EME or QSE which is at least 100% owned by black people	10
an EME or QSE which is at least 51% - 99% owned by black people	6
an EME or QSE which is at 25% - 50% owned by black people;	4
Total points for Price and SPECIFIC GOALS	20

SAMPLES WILL BE REQUESTED BY THE BEC FOR FURTHER EVALUATION.

**COMPANIES WILL BE DISQUALIFIED FOR NOT SUBMITTING ALL SAMPLES ON TIME.
THE QUALITY OF SAMPLES ARE INCLUDED IN THE SPECIFICATIONS**

NOTE TO BIDDERS ON CONDITIONS OF THE BID:

- The Supply Chain Management Policy of Ray Nkonyeni Municipality will apply. The Council reserves the right not to accept the lowest bid or any bid and reserves the right to accept the whole or part of the bid, or to reject all bids and cancel the notice to bid;
- Bids that are submitted late, incomplete, not initialled on each page, unsigned or by facsimile, electronically or not completed in black ink will be rejected and not accepted for further evaluation;
- Only service providers registered in the Central Supplier Database (CSD) will be considered, attach proof of registration failure to attach will result in your bid not evaluated further.
- Members or Directors of Companies or Service Providers who are state employees are not allowed to bid or quote;
- Unsuccessful bidders will be informed of the Bid outcome through the Municipal website Aggrieved unsuccessful bidders will be allowed to lodge, within fourteen (14) days of the decision or action, a written objection or complaint to the Office of the Municipal Manager through email, mm@rnm.gov.za or fax number 0865297195. Complaints or objections received after fourteen (14) days of the date of the notice **will not** be entertained; and
- The original bid document plus One **extra** (01) copy must be submitted, failure to submit one copies will result in disqualification.
- Bids submitted are to be valid for a period of **120 days**.

KJ ZULU
MUNICIPAL MANAGER
P.O. Box 5
PORT SHEPSTONE, 4240

**ALL BIDS MUST BE SUBMITTED ON THE OFFICIAL FORMS
(NOT TO BE RE-TYPED)**

NB!!!! Please attach copies of the following documents.

- **Company registration documents.**
- **Certified copy of ID documents of directors/owners/members/
shareholders.**
- **Copy of a valid TAX Compliance Certificate
Or Tax Compliance Status PIN Sheet.**
- **Declarations (MBD 4, 6.1, 8 & 9).**
- **Joint Venture agreements (where applicable)**



THIS BID IS SUBJECT TO THE GENERAL CONDITIONS OF CONTRACT (GCC) AND, IF APPLICABLE, ANY OTHER SPECIAL CONDITIONS OF CONTRACT. THIS BID WILL BE EVALUATED AND ADJUDICATED ACCORDING TO THE FOLLOWING CRITERIA:

1. Relevant specifications
2. Value for money
3. Capability to execute the contract
4. PPPFA & associated regulations

NB: NO BIDS WILL BE CONSIDERED FROM PERSONS IN THE SERVICE OF THE STATE

<h2 style="margin: 0;">RAY NKONYENI MUNICIPALITY STANDARD FORM FOR BIDS</h2>
--

YOU ARE HEREBY INVITED TO BID FOR REQUIREMENTS OF THE RAY NKONYENI MUNICIPALITY					
BID NUMBER:	8/2/RNM0647	CLOSING DATE:	6 JULY 2026	CLOSING TIME:	12:00
DESCRIPTION	Supply And Delivery of Fire Fighting Uniform for Fire Personnel For A Period Of Three (3) Years				
THE SUCCESSFUL BIDDER WILL BE REQUIRED TO FILL IN AND SIGN A WRITTEN CONTRACT FORM (MBD7).					

BID RESPONSE DOCUMENTS MAY BE DEPOSITED IN THE BID BOX
SITUATED AT (STREET ADDRESS)

RAY NKONYENI MUNICIPALITY
PO BOX 5
PORT SHEPSTONE (10 Connor Street)
4240

SUPPLIER INFORMATION					
NAME OF BIDDER					
POSTAL ADDRESS					
STREET ADDRESS					
TELEPHONE NUMBER	CODE		NUMBER		
CELLPHONE NUMBER					
FACSIMILE NUMBER	CODE		NUMBER		
E-MAIL ADDRESS					
VAT REGISTRATION NUMBER					
TAX COMPLIANCE STATUS	TCS PIN:		OR	CSD No:	

ARE YOU THE ACCREDITED REPRESENTATIVE IN SOUTH AFRICA FOR THE GOODS /SERVICES /WORKS OFFERED?	<input type="checkbox"/> Yes <input type="checkbox"/> No [IF YES ENCLOSE PROOF]	ARE YOU A FOREIGN BASED SUPPLIER FOR THE GOODS /SERVICES /WORKS OFFERED?	<input type="checkbox"/> Yes <input type="checkbox"/> No [IF YES, ANSWER PART B:3]
TOTAL NUMBER OF ITEMS OFFERED		TOTAL BID PRICE	R
SIGNATURE OF BIDDER	DATE	
CAPACITY UNDER WHICH THIS BID IS SIGNED			

BIDDING PROCEDURE ENQUIRIES MAY BE DIRECTED TO:		TECHNICAL INFORMATION MAY BE DIRECTED TO:	
DEPARTMENT	TREASURY SCM		PUBLIC SAFETY
CONTACT PERSON	MR BONGANI MFENQA	TELEPHONE NUMBER	MR P. RAMCHANDER
TELEPHONE NUMBER	039-3128304	FACSIMILE NUMBER	0616612992
E-MAIL ADDRESS	Bongani.Mfenqa@rnm.gov.za	E-MAIL ADDRESS	Pravesh.Ramchander@rnm.gov.za

**PART B
TERMS AND CONDITIONS FOR BIDDING**

1. BID SUBMISSION:	
1.1.	BIDS MUST BE DELIVERED BY THE STIPULATED TIME TO THE CORRECT ADDRESS. LATE BIDS WILL NOT BE ACCEPTED FOR CONSIDERATION.
1.2.	ALL BIDS MUST BE SUBMITTED ON THE OFFICIAL FORMS PROVIDED-(NOT TO BE RE-TYPED) OR ONLINE
1.3.	THIS BID IS SUBJECT TO THE PREFERENTIAL PROCUREMENT POLICY FRAMEWORK ACT AND THE PREFERENTIAL PROCUREMENT REGULATIONS, 2022, THE GENERAL CONDITIONS OF CONTRACT (GCC) AND, IF APPLICABLE, ANY OTHER SPECIAL CONDITIONS OF CONTRACT.
1.4.	THE BID OFFER MUST BE SIGNED BY A PERSON AUTHORIZED TO SIGN ON BEHALF OF THE BIDDER;
1.5.	A BIDDER WHO SUBMITTED A BID AS A JOINT VENTURE HAS INCLUDED AN ACCEPTABLE JOINT VENTURE AGREEMENT WITH HIS/HER BID;
1.6.	A BIDDER WHO IS A JOINT VENTURE HAS INCLUDED MBD 4, 8 & 9 FOR EACH ENTITY IN THE JOINT VENTURE / CONSORTIUM WITH HIS/HER BID
2. TAX COMPLIANCE REQUIREMENTS	
2.1	BIDDERS MUST ENSURE COMPLIANCE WITH THEIR TAX OBLIGATIONS.
2.2	BIDDERS ARE REQUIRED TO SUBMIT THEIR UNIQUE PERSONAL IDENTIFICATION NUMBER (PIN) ISSUED BY SARS TO ENABLE THE ORGAN OF STATE TO VIEW THE TAXPAYER'S PROFILE AND TAX STATUS.
2.3	APPLICATION FOR THE TAX COMPLIANCE STATUS (TCS) CERTIFICATE OR PIN MAY ALSO BE MADE VIA E-FILING. IN ORDER TO USE THIS PROVISION, TAXPAYERS WILL NEED TO REGISTER WITH SARS AS E-FILERS THROUGH THE WEBSITE WWW.SARS.GOV.ZA.
2.4	FOREIGN SUPPLIERS MUST COMPLETE THE PRE-AWARD QUESTIONNAIRE IN PART B:3.
2.5	BIDDERS MAY ALSO SUBMIT A PRINTED TCS CERTIFICATE TOGETHER WITH THE BID.
2.6	IN BIDS WHERE CONSORTIA / JOINT VENTURES / SUB-CONTRACTORS ARE INVOLVED, EACH PARTY MUST SUBMIT A SEPARATE TCS CERTIFICATE / PIN / CSD NUMBER.
2.7	WHERE NO TCS IS AVAILABLE BUT THE BIDDER IS REGISTERED ON THE CENTRAL SUPPLIER DATABASE (CSD), A CSD NUMBER MUST BE PROVIDED.
3. QUESTIONNAIRE TO BIDDING FOREIGN SUPPLIERS	
3.1.	IS THE ENTITY A RESIDENT OF THE REPUBLIC OF SOUTH AFRICA (RSA)? <input type="checkbox"/> YES <input type="checkbox"/> NO
3.2.	DOES THE ENTITY HAVE A BRANCH IN THE RSA? <input type="checkbox"/> YES <input type="checkbox"/> NO
3.3.	DOES THE ENTITY HAVE A PERMANENT ESTABLISHMENT IN THE RSA? <input type="checkbox"/> YES <input type="checkbox"/> NO
3.4.	DOES THE ENTITY HAVE ANY SOURCE OF INCOME IN THE RSA? <input type="checkbox"/> YES <input type="checkbox"/> NO
3.5.	IS THE ENTITY LIABLE IN THE RSA FOR ANY FORM OF TAXATION? <input type="checkbox"/> YES <input type="checkbox"/> NO
IF THE ANSWER IS "NO" TO ALL OF THE ABOVE, THEN IT IS NOT A REQUIREMENT TO REGISTER FOR A TAX COMPLIANCE STATUS SYSTEM PIN CODE FROM THE SOUTH AFRICAN REVENUE SERVICE (SARS) AND IF NOT REGISTER AS PER 2.3 ABOVE.	

**NB: FAILURE TO PROVIDE ANY OF THE ABOVE PARTICULARS MAY RENDER THE BID INVALID.
NO BIDS WILL BE CONSIDERED FROM PERSONS IN THE SERVICE OF THE STATE.**

SIGNATURE OF BIDDER:

CAPACITY UNDER WHICH THIS BID IS SIGNED:

DATE:

EVALUATION OF TENDER OFFERS

The procedure for evaluation of responsive Bid Offers will be **METHOD 2** if applicable to your bid: (Financial Offer, preference with 80/20 Preference Points System. Score quality, rejecting all Bid Offers that fail to score the minimum number of points for quality stated in the Bid Data. The total score awarded will be the addition of the two scores for price and preference.

The following formula will be used in Calculation of Percentage for Functionality

$$PS = \frac{So \times Ap}{Ms}$$

Where:

Ps = percentage scored for functionality by Bid/proposal under consideration

So = total score of bid/proposal under consideration

Ms = Maximum possible score

Ap = percentage allocated for functionality

GENERAL CONDITIONS OF CONTRACT TABLE OF CLAUSES

1. Definitions
2. Application
3. General
4. Standards
5. Use of contract documents and information inspection
6. Patent Rights
7. Performance security
8. Inspections, tests and analyses
9. Packing
10. Delivery and documents
11. Insurance
12. Transportation
13. Incidental Services
14. Spare parts
15. Warranty
16. Payment
17. Prices
18. Variation orders
19. Assignment
20. Subcontracts
21. Delays in the supplier's performance
22. Penalties
23. Termination for default
24. Anti-dumping and countervailing duties and rights
25. Force Majeure
26. Termination for insolvency
27. Settlement of Disputes
28. Limitation of Liability
29. Governing language
30. Applicable law
31. Notices
32. Taxes and duties
33. Transfer of contracts
34. Amendments of contracts
35. Prohibition of restrictive practices

General Conditions of Contract

- 1. Definitions**
 - 1.1 The following terms shall be interpreted as indicated:
 - 1.2 “Closing time” means the date and hour specified in the bidding documents for the receipt of bids.
 - 1.3 “Contract” means the written agreement entered into between the purchaser and the supplier, as recorded in the contract form signed by the parties, including all attachments and appendices thereto and all documents incorporated by reference therein.
 - 1.4 “Contract price” means the price payable to the supplier under the contract for the full and proper performance of his contractual obligations.
 - 1.5 “Corrupt practice” means the offering, giving, receiving, or soliciting of anything of value to influence the action of a public official in the procurement process or in contract execution.
 - 1.6 "Countervailing duties" are imposed in cases where an enterprise abroad is subsidized by its government and encouraged to market its products internationally.
 - 1.7 “Country of origin” means the place where the goods were mined, grown or produced or from which the services are supplied. Goods are produced when, through manufacturing, processing or substantial and major assembly of components, commercially recognized new product results that is substantially different in basic characteristics or in purpose or utility from its components.
 - 1.8. “Database application form” means the application form required by the Ray Nkonyeni Municipality to be filled in by the successful Bidder, following the award of the contract, for inclusion on the RNM database before payment is made.
 - 1.9 “Day” means calendar day.
 - 1.10 “Delivery” means delivery in compliance of the conditions of the contract or order.
 - 1.11 “Delivery ex stock” means immediate delivery directly from stock actually on hand.
 - 1.12 “Delivery into consignees store or to his site” means delivered and unloaded in the specified store or depot or on the specified site in compliance with the conditions of the contract or order, the supplier bearing all risks and charges involved until the goods are so delivered and a valid receipt is obtained.
 - 1.13 "Dumping" occurs when a private enterprise abroad market its goods on own initiative in the RSA at lower prices than that of the country of origin and which have the potential to harm the local industries in the RSA.

- 1.14 "Force majeure" means an event beyond the control of the supplier and not involving the supplier's fault or negligence and not foreseeable. Such events may include, but is not restricted to, acts of the purchaser in its sovereign capacity, wars or revolutions, fires, floods, epidemics, quarantine restrictions and freight embargoes.
- 1.15 "Fraudulent practice" means a misrepresentation of facts in order to influence a procurement process or the execution of contract to the detriment of any bidder, and includes collusive practice among bidders (prior to or after bid submission) designed to establish bid prices at artificial non-competitive levels and to deprive the bidder of the benefits of free and open competition.
- 1.16 "GCC" means the General Conditions of Contract.
- 1.17 "Goods" means all of the equipment, machinery, and/or other materials that the supplier is required to supply to the purchaser under the contract.
- 1.18 "Imported content" means that portion of the bidding price represented by the cost of components, parts or materials which have been or are still to be imported (whether by the supplier or his subcontractors) and which costs are inclusive of the costs abroad, plus freight and other direct importation costs such as landing costs, dock dues, import duty, sales duty or other similar tax or duty at the South African place of entry as well as transportation and handling charges to the factory in the Republic where the goods covered by the bid will be manufactured.
- 1.19 "Local content" means that portion of the bidding price, which is not included in the imported content provided that local manufacture does take place.
- 1.20 "Manufacture" means the production of products in a factory using labour, materials, components and machinery and includes other related value-adding activities.
- 1.21 "Order" means an official written order issued for the supply of goods or works or the rendering of a service.
- 1.22 "Project site," where applicable, means the place indicated in bidding documents.
- 1.23 "Purchaser" means the organization purchasing the goods.
- 1.24 "Republic" means the Republic of South Africa.
- 1.25 "SCC" means the Special Conditions of Contract.
- 1.26 "Services" means those functional services ancillary to the supply of the goods, such as transportation and any other incidental services, such as installation, commissioning, provision of technical assistance, training, catering, gardening, security, maintenance and other such obligations of the supplier covered under the contract.

- 1.27 “Supplier” means the successful bidder who is awarded the contract to maintain and administer the required and specified service(s) to the State.
- 1.28 “Tort” means in breach of contract.
- 1.29 “Turnkey” means a procurement process where one service provider assumes total responsibility for all aspects of the project and delivers the full end product / service required by the contract.
- 1.30 “Written” or “in writing” means hand-written in ink or any form of electronic or mechanical writing.
- 2. Application**
- 2.1 These general conditions are applicable to all bids, contracts and orders including bids for functional and professional services (excluding professional services related to the building and construction industry), sales, hiring, letting and the granting or acquiring of rights, but excluding immovable property, unless otherwise indicated in the bidding documents.
- 2.2 Where applicable, special conditions of contract are also laid down to cover specific goods, services or works.
- 2.3 Where such special conditions of contract are in conflict with these general conditions, the special conditions shall apply.
- 3. General**
- 3.1 Unless otherwise indicated in the bidding documents, the purchaser shall not be liable for any expense incurred in the preparation and submission of a bid. Where applicable a nonrefundable fee for documents may be charged.
- 3.2 Invitations to bid are usually published in locally distributed news media and on the municipality/municipal entity website.
- 4. Standards**
- 4.1 The goods supplied shall conform to the standards mentioned in the bidding documents and specifications.
- 5. Use of contract documents and information inspection**
- 5.1 The supplier shall not, without the purchaser’s prior written consent, disclose the contract, or any provision thereof, or any specifications, plan, drawing, pattern, sample, or information furnished by or on behalf of the purchaser in connection therewith, to any person other than a person employed by the supplier in the of the contract. Disclosure to any such employed person shall be made in confidence and shall extend only so far as may be necessary for purposes of such performance.
- 5.2 The supplier shall not, without the purchaser’s prior written consent, make use of any document or information mentioned in GCC clause 5.1 except for purposes of performing the contract.
- 5.3 Any document, other than the contract itself mentioned in GCC clause 5.1 shall remain the property of the purchaser and shall be returned

(all copies) to the purchaser on completion of the supplier's performance under the contract if so required by the purchaser.

5.4 The supplier shall permit the purchaser to inspect the supplier's records relating to the performance of the supplier and to have them audited by auditors appointed by the purchaser, if so required by the purchaser.

6. Patent rights 6.1 The supplier shall indemnify the purchaser against all third party claims of infringement of patent, trademark, or industrial design rights arising from use of the goods or any part thereof by the purchaser.

6.2 When a supplier developed documentation / projects for the municipality / municipal entity, the intellectual, copy and patent rights or ownership of such documents or projects will vest in the municipality / municipal entity.

7. Performance security 7.1 Within thirty (30) days of receipt of the notification of contract award, the successful bidder shall furnish to the purchaser the performance security of the amount specified in SCC.

7.2 The proceeds of the performance security shall be payable to the purchaser as compensation for any loss resulting from the supplier's failure to complete his obligations under the contract.

7.3 The performance security shall be denominated in the currency of the contract, or in a freely convertible currency acceptable to the purchaser and shall be in one of the following forms:

- (a) a bank guarantee or an irrevocable letter of credit issued by a reputable bank located in the purchaser's country or abroad, acceptable to the purchaser, in the form provided in the bidding documents or another form acceptable to the purchaser; or
- (b) a cashier's or certified cheque.

7.4 The performance security will be discharged by the purchaser and returned to the supplier not later than thirty (30) days following the date of completion of the supplier's performance obligations under the contract, including any warranty obligations, unless otherwise specified.

8. Inspections, tests and analyses 8.1 All pre-bidding testing will be for the account of the bidder.

8.2 If it is a bid condition that goods to be produced or services to be rendered should at any stage be subject to inspections, tests and analyses, the bidder or contractor's premises shall be open, at all reasonable hours, for inspection by a representative of the purchaser or organization acting on behalf of the purchaser.

8.3 If there are no inspection requirements indicated in the bidding documents and no mention is made in the contract, but during the

contract period it is decided that inspections shall be carried out, the purchaser shall itself make the necessary arrangements, including payment arrangements with the testing authority concerned.

- 8.4 If the inspections, tests and analyses referred to in clauses 8.2 and 8.3 show the goods to be in accordance with the contract requirements, the cost of the inspections, tests and analyses shall be defrayed by the purchaser.
- 8.5 Where the goods or services referred to in clauses 8.2 and 8.3 do not comply with the contract requirements, irrespective of whether such goods or services are accepted or not, the cost in connection with these inspections, tests or analyses shall be defrayed by the supplier.
- 8.6 Goods and services which are referred to in clauses 8.2 and 8.3 and which do not comply with the contract requirements may be rejected.
- 8.7 Any contract goods may on or after delivery be inspected, tested or analyzed and may be rejected if found not to comply with the requirements of the contract. Such rejected goods shall be held at the cost and risk of the supplier who shall, when called upon, remove them immediately at his own cost and forthwith substitute them with goods, which do comply with the requirements of the contract. Failing such removal the rejected goods shall be returned at the suppliers cost and risk. Should the supplier fail to provide the substitute goods forthwith, the purchaser may, without giving the supplier further opportunity to substitute the rejected goods, purchase such goods as may be necessary at the expense of the supplier.
- 8.8 The provisions of clauses 8.4 to 8.7 shall not prejudice the right of the purchaser to cancel the contract on account of a breach of the conditions thereof, or to act in terms of Clause 22 of GCC.
- 9. Packing**
- 9.1 The supplier shall provide such packing of the goods as is required to prevent their damage or deterioration during transit to their final destination, as indicated in the contract. The packing shall be sufficient to withstand, without limitation, rough handling during transit and exposure to extreme temperatures, salt and precipitation during transit, and open storage. Packing, case size weights shall take into consideration, where appropriate, the remoteness of the goods' final destination and the absence of heavy handling facilities at all points in transit.
- 9.2 The packing, marking, and documentation within and outside the packages shall comply strictly with such special requirements as shall be expressly provided for in the contract, including additional requirements, if any, and in any subsequent instructions ordered by the purchaser.
- 10. Delivery and documents**
- 10.1 Delivery of the goods and arrangements for shipping and clearance obligations, shall be made by the supplier in accordance with the terms specified in the contract.
- 11. Insurance**
- 11.1 The goods supplied under the contract shall be fully

insured in freely convertible currency against loss or damage incidental to manufacture or acquisition, transportation, storage and delivery in the manner specified.

- 12. Transportation** 12.1 Should a price other than an all-inclusive delivered price be required, this shall be specified.
- 13. Incidental services** 13.1 The supplier may be required to provide any or all of the following services, including additional services, if any:
- (a) performance or supervision of on-site assembly and/or commissioning of the supplied goods;
 - (b) furnishing of tools required for assembly and/or maintenance of the supplied goods;
 - (c) furnishing of a detailed operations and maintenance manual for each appropriate unit of the supplied goods;
 - (d) performance or supervision or maintenance and/or repair of the supplied goods, for a period of time agreed by the parties, provided that this service shall not relieve the supplier of any warranty obligations under this contract; and
 - (e) training of the purchaser's personnel, at the supplier's plant and/or on-site, in assembly, start-up, operation, maintenance, and/or repair of the supplied goods.
- 13.2 Prices charged by the supplier for incidental services, if not included in the contract price for the goods, shall be agreed upon in advance by the parties and shall not exceed the prevailing rates charged to other parties by the supplier for similar services.
- 14. Spare parts** 14.1 As specified, the supplier may be required to provide any or all of the following materials, notifications, and information pertaining to spare parts manufactured or distributed by the supplier:
- (a) such spare parts as the purchaser may elect to purchase from the supplier, provided that this election shall not relieve the supplier of any warranty obligations under the contract; and
 - (b) in the event of termination of production of the spare parts:
 - (i) advance notification to the purchaser of the pending termination, in sufficient time to permit the purchaser to procure needed requirements; and
 - (ii) following such termination, furnishing at no cost to the purchaser, the blueprints, drawings, and specifications of the spare parts, if requested.
- 15. Warranty** 15.1 The supplier warrants that the goods supplied under the contract are new, unused, of the most recent or current models, and that they incorporate all recent improvements in design and materials unless provided otherwise in the contract. The supplier further

warrants that all goods supplied under this contract shall have no defect, arising from design, materials, or workmanship (except when the design and/or material is required by the purchaser's specifications) or from any act or omission of the supplier, that may develop under normal use of the supplied goods in the conditions prevailing in the country of final destination.

- 15.2 This warranty shall remain valid for twelve (12) months after the goods, or any portion thereof as the case may be, have been delivered to and accepted at the final destination indicated in the contract, or for eighteen (18) months after the date of shipment from the port or place of loading in the source country, whichever period concludes earlier, unless specified otherwise.
- 15.3 The purchaser shall promptly notify the supplier in writing of any claims arising under this warranty.
- 15.4 Upon receipt of such notice, the supplier shall, within the period specified and with all reasonable speed, repair or replace the defective goods or parts thereof, without costs to the purchaser.
- 15.5 If the supplier, having been notified, fails to remedy the defect(s) within the period specified, the purchaser may proceed to take such remedial action as may be necessary, at the supplier's risk and expense and without prejudice to any other rights which the purchaser may have against the supplier under the contract.

16. Payment

- 16.1 The method and conditions of payment to be made to the supplier under this contract shall be specified.
- 16.2 The supplier shall furnish the purchaser with an invoice accompanied by a copy of the delivery note and upon fulfillment of other obligations stipulated in the contract.
- 16.3 Payments shall be made promptly by the purchaser, but in no case later than thirty (30) days after submission of an invoice or claim by the supplier.
- 16.4 Payment will be made in Rand unless otherwise stipulated.
- 16.5. Payment will only be made if the supplier has filled in and submitted the necessary database application form to the satisfaction of the Chief Financial Officer.

17. Prices

- 17.1 Prices charged by the supplier for goods delivered and services performed under the contract shall not vary from the prices quoted by the supplier in his bid, with the exception of any price adjustments authorized or in the purchaser's request for bid validity extension, as the case may be.

18. Variation orders

- 18.1 In cases where the estimated value of the envisaged changes in purchase does not vary more than 15% of the total value of the original contract, the contractor may be instructed to deliver the goods or render the services as such. In cases of measurable

quantities, the contractor may be approached to reduce the unit price, and such offers may be accepted provided that there is no escalation in price.

- 19. Assignment** 19.1 The supplier shall not assign, in whole or in part, its obligations to perform under the contract, except with the purchaser's prior written consent.
- 20. Subcontracts** 20.1 The supplier shall notify the purchaser in writing of all sub-contracts awarded under this contracts if not already specified in the bid. Such notification, in the original bid or later, shall not relieve the supplier from any liability or obligation under the contract.
- 21. Delays in the supplier's performance** 21.1 Delivery of the goods and performance of services shall be made by the supplier in accordance with the time schedule prescribed by the purchaser in the contract.
- 21.2 If at any time during performance of the contract, the supplier or its subcontractor(s) should encounter conditions impeding timely delivery of the goods and performance of services, the supplier shall promptly notify the purchaser in writing of the fact of the delay, its likely duration and its cause(s). As soon as practicable after receipt of the supplier's notice, the purchaser shall evaluate the situation and may at his discretion extend the supplier's time for performance, with or without the imposition of penalties, in which case the extension shall be ratified by the parties by amendment of contract.
- 21.3 The right is reserved to procure outside of the contract small quantities or to have minor essential services executed if an emergency arises, the supplier's point of supply is not situated at or near the place where the goods are required, or the supplier's services are not readily available.
- 21.4 Except as provided under GCC Clause 25, a delay by the supplier in the performance of its delivery obligations shall render the supplier liable to the imposition of penalties, pursuant to GCC Clause 22, unless an extension of time is agreed upon pursuant to GCC Clause 22.2 without the application of penalties.
- 21.5 Upon any delay beyond the delivery period in the case of a goods contract, the purchaser shall, without cancelling the contract, be entitled to purchase goods of a similar quality and up to the same quantity in substitution of the goods not supplied in conformity with the contract and to return any goods delivered later at the supplier's expense and risk, or to cancel the contract and buy such goods as may be required to complete the contract and without prejudice to his other rights, be entitled to claim damages from the supplier.
- 22. Penalties** 22.1 Subject to GCC Clause 25, if the supplier fails to deliver any or all of the goods or to perform the services within the period(s) specified in the contract, the purchaser shall, without prejudice to its other remedies under the contract, deduct from the contract price, as a penalty, a sum calculated on the delivered price of

the delayed goods or unperformed services using the current prime interest rate calculated for each day of the delay until actual delivery or performance. The purchaser may also consider termination of the contract pursuant to GCC Clause 23.

23. Termination for default

- 23.1 The purchaser, without prejudice to any other remedy for breach of contract, by written notice of default sent to the supplier, may terminate this contract in whole or in part:
- (a) if the supplier fails to deliver any or all of the goods within the period(s) specified in the contract, or within any extension thereof granted by the purchaser pursuant to GCC Clause 21.2;
 - (b) if the supplier fails to perform any other obligation(s) under the contract; or
 - (c) if the supplier, in the judgement of the purchaser, has engaged in corrupt or fraudulent practices in competing for or in executing the contract.
- 23.2 In the event the purchaser terminates the contract in whole or in part, the purchaser may procure, upon such terms and in such manner, as it deems appropriate, goods, works or services similar to those undelivered, and the supplier shall be liable to the purchaser for any excess costs for such similar goods, works or services. However, the supplier shall continue performance of the contract to the extent not terminated.
- 23.3 Where the purchaser terminates the contract in whole or in part, the purchaser may decide to impose a restriction penalty on the supplier by prohibiting such supplier from doing business with the public sector for a period not exceeding 10 years.
- 23.4 If a purchaser intends imposing a restriction on a supplier or any person associated with the supplier, the supplier will be allowed a time period of not more than fourteen (14) days to provide reasons why the envisaged restriction should not be imposed. Should the supplier fail to respond within the stipulated fourteen (14) days the purchaser may regard the supplier as having no objection and proceed with the restriction.
- 23.5 Any restriction imposed on any person by the purchaser will, at the discretion of the purchaser, also be applicable to any other enterprise or any partner, manager, director or other person who wholly or partly exercises or exercised or may exercise control over the enterprise of the first-mentioned person, and with which enterprise or person the first-mentioned person, is or was in the opinion of the purchaser actively associated.
- 23.6 If a restriction is imposed, the purchaser must, within five (5) working days of such imposition, furnish the National Treasury, with the following information:

- (a) the name and address of the supplier and / or person restricted by the purchaser;
- (b) the date of commencement of the restriction;
- (c) the period of restriction; and
- (d) the reasons for the restriction.

These details will be loaded in the National Treasury's central database of suppliers or persons prohibited from doing business with the public sector.

23.7 If a court of law convicts a person of an offence as contemplated in sections 12 or 13 of the Prevention and Combating of Corrupt Activities Act, No. 12 of 2004, the court may also rule that such person's name be endorsed on the Register for Bid Defaulters. When a person's name has been endorsed on the Register, the person will be prohibited from doing business with the public sector for a period not less than five years and not more than 10 years. The National Treasury is empowered to determine the period of restriction and each case will be dealt with on its own merits. According to section 32 of the Act the Register must be open to the public. The Register can be perused on the National Treasury website.

24. Anti-dumping and countervailing duties and rights

24.1 When, after the date of bid, provisional payments are required, or anti-dumping or countervailing duties are imposed, or the amount of amount of a provisional payment or anti-dumping or countervailing right is increased in respect of any dumped or subsidized import, the State is not liable for any amount so required or imposed, or for the amount of any such increase. When, after the said date, such a provisional payment is no longer required or any such anti-dumping or countervailing right is abolished, or where the amount of such provisional payment or any such right is reduced, any such favorable difference shall on demand be paid forthwith by the supplier to the purchaser or the purchaser may deduct such amounts from moneys (if any) which may otherwise be due to the supplier in regard to goods or services which he delivered or rendered, or is to deliver or render in terms of the contract or any other contract or any other amount which may be due to him.

25. Force majeure

25.1 Notwithstanding the provisions of GCC Clauses 22 and 23, the supplier shall not be liable for forfeiture of its performance security, damages, or termination for default if and to the extent that his delay in performance or other failure to perform his obligations under the contract is the result of an event of force majeure.

25.2 If a force majeure situation arises, the supplier shall promptly notify the purchaser in writing of such condition and the cause thereof. Unless otherwise directed by the purchaser in writing, the supplier shall continue to perform its obligations under the contract as far as is reasonably practical, and shall seek all reasonable alternative means for performance not prevented by the force majeure event.

26. Termination

26.1 The purchaser may at any time terminate the contract by giving

	for insolvency		written notice to the supplier if the supplier becomes bankrupt or otherwise insolvent. In this event, termination will be without compensation to the supplier, provided that such termination will not prejudice or affect any right of action or remedy, which has accrued or will accrue thereafter to the purchaser.
27.	Settlement of disputes	27.1	If any dispute or difference of any kind whatsoever arises between the purchaser and the supplier in connection with or arising out of the contract, the parties shall make every effort to resolve amicably such dispute or difference by mutual consultation.
		27.2	If, after thirty (30) days, the parties have failed to resolve their dispute or difference by such mutual consultation, then either the purchaser or the supplier may give notice to the other party of his intention to commence with mediation. No mediation in respect of this matter may be commenced unless such notice is given to the other party.
		27.3	Should it not be possible to settle a dispute by means of mediation, it may be settled in a South African court of law.
		27.4	Notwithstanding any reference to mediation and/or court proceedings herein, <ul style="list-style-type: none"> (a) the parties shall continue to perform their respective obligations under the contract unless they otherwise agree; and (b) the purchaser shall pay the supplier any monies due the supplier for goods delivered and / or services rendered according to the prescripts of the contract.
28.	Limitation of liability	28.1	Except in cases of criminal negligence or willful misconduct, and in the case of infringement pursuant to Clause 6; <ul style="list-style-type: none"> (a) the supplier shall not be liable to the purchaser, whether in contract, tort, or otherwise, for any indirect or consequential loss or damage, loss of use, loss of production, or loss of profits or interest costs, provided that this exclusion shall not apply to any obligation of the supplier to pay penalties and/or damages to the purchaser; and (b) the aggregate liability of the supplier to the purchaser, whether under the contract, in tort or otherwise, shall not exceed the total contract price, provided that this limitation shall not apply to the cost of repairing or replacing defective equipment.
29.	Governing language	29.1	The contract shall be written in English. All correspondence and other documents pertaining to the contract that is exchanged by the parties shall also be written in English.
30.	Applicable law	30.1	The contract shall be interpreted in accordance with South African laws, unless otherwise specified.
31.	Notices	31.1	Every written acceptance of a bid shall be posted to the Supplier

concerned by registered or certified mail and any other notice to him shall be posted by ordinary mail to the address furnished in his bid or to the address notified later by him in writing and such posting shall be deemed to be proper service of such notice.

- 31.2 The time mentioned in the contract documents for performing any act after such aforesaid notice has been given, shall be reckoned from the date of posting of such notice.
- 32. Taxes and duties**
- 32.1 A foreign supplier shall be entirely responsible for all taxes, stamp duties, license fees, and other such levies imposed outside the purchaser's country.
- 32.2 A local supplier shall be entirely responsible for all taxes, duties, license fees, etc., incurred until delivery of the contracted goods to the purchaser.
- 32.3 No contract shall be concluded with any bidder whose tax matters are not in order. Prior to the award of a bid SARS must have certified that the tax matters of the preferred bidder are in order.
- 32.4 No contract shall be concluded with any bidder whose municipal rates and taxes and municipal services charges are in arrears.
- 33. Transfer of contracts**
- 33.1 The contractor shall not abandon, transfer, cede assign or sublet a contract or part thereof without the written permission of the purchaser.
- 34. Amendment of contracts**
- 34.1 No agreement to amend or vary a contract or order or the conditions, stipulations or provisions thereof shall be valid and of any force unless such agreement to amend or vary is entered into in writing and signed by the contracting parties. Any waiver of their requirement that the agreement to amend or vary shall be in writing, shall also be in writing.
- 35. Prohibition of restrictive practices**
- 35.1 In terms of section 4 (1) (b) (iii) of the Competition Act No. 89 of 1998 as amended, an agreement between, or concerted practice by , firms or a decision by an association of firms, is prohibited if it is between parties in a horizontal relationship and if a bidder(s) is/ are or a contractor(s) was / were involved in collusive bidding.
- 35.2 If a bidder(s) or contractor(s) based on reasonable grounds or evidence obtained by the purchaser has / have engaged in the restrictive practice referred to above, the purchaser may refer the matter to the Competition Commission for investigation and possible imposition of administrative penalties as contemplated in section 59 of the Competition Act No 89 Of 1998.
- 35.3 If a bidder(s) or contractor(s) has / have been found guilty by the Competition Commission of the restrictive practice referred to above, the purchaser may, in addition and without prejudice to any other remedy provided for, invalidate the bid(s) for such item(s) offered, and / or terminate the contract in whole or part, and / or restrict the bidder(s) or contractor(s) from conducting business with the public sector for a period not exceeding ten (10) years and / or claim damages from the bidder(s) or contractor(s) concerned.

No contract will be awarded to a person who has failed to submit a copy of Tax Compliance Certificate with a PIN from the South African Revenue Service (“SARS”) certifying that the taxes of that person to be in order or that suitable arrangements have been made with SARS.

I certify that I have the appropriate authority to furnish the above-mentioned information and that the above information is correct at the time of completion.

Name:	Signature:
Designation:	Date:

**PRICING SCHEDULE – NON-FIRM PRICES
(PURCHASES)**

NOTE: PRICE ADJUSTMENTS WILL BE ALLOWED AT THE PERIODS AND TIMES SPECIFIED IN THE BIDDING DOCUMENTS.

IN CASES WHERE DIFFERENT DELIVERY POINTS INFLUENCE THE PRICING, A SEPARATE PRICING SCHEDULE MUST BE SUBMITTED FOR EACH DELIVERY POINT

Name of Bidder.....	Bid number.....
Closing Time	Closing Date
.....	

OFFER TO BE VALID FOR.....DAYS FROM THE CLOSING DATE OF BID.

 ITEM QUANTITY DESCRIPTION BID PRICE IN RSA CURRENCY
 NO. **(ALL APPLICABLE TAXES INCLUDED)

/ We hereby quote / tender for the following: Supply and Delivery of Fire Fighting Uniform for Fire Personnel for a three-year period.

This quote/tender is valid for a period of 120 Days.

- These prices quoted are non-firm
- Escalation will be made annually based on the average CPI of each completed year of the tender awarded.

	unit price Excluding VAT	
	SIZE	R
White long sleeve Shirts	S/37	
	M/39	
	L/42	
	XL/46	
	2XL/48	
Black Trousers	30	
	32	
	34	
	36	
	38	
	40	
	42	
	44	
Black Polyester/wool ladies Skirts	28	
	32	
	40	
	42	

	44	
	46	
Shoes Black Parabellum	5	
	6	
	7	
	8	
	9	
	10	
	11	
	12	
Elastic Half Boot	5	
	6	
	7	
	8	
	9	
	10	
	11	
	12	
White Short Sleeve Shirt	S	
	M	
	L	
	XI	
	2xl	
Charcoal Grey T Shirt- with logo	S	
	M	
	L	
	XI	
	2xl	
Black Biogard Socks		
Navy Combat Trousers	30	
	32	
	34	
	36	
	38	
	40	
	42	
	44	
Black Anoraks	S	
	M	
	L	
	XI	
	Xxl	
Black Webbing Belts with Fire logos	M	
	L	

Epaulettes		
Flashers		
Navy Short Sleeve Combat Shirts	S	
	M	
	L	
	XL	
	2XL	
Baseball caps		
Step out gloves	S	
	M	
	L	
	XL	
Knitted Beanies		
Raincoats	S	
	M	
	L	
	XL	
	2XL	
Metalette ID shield		
Bunny Jacket with Logo	S	
	M	
	L	
	XL	
	2XL	
Golfer tee shirts with Logo [Collar]	S	
	M	
	L	
	XL	
	2XL	
Peak Caps		
Tie		
Lanyard		
	Sub-total R	
	Plus 15% VAT R	
	TOTAL R	

SPECIFICATIONS FIRE FIGHTING UNIFORM

ITEM 1. WHITE LONG SLEEVE SHIRTS

Fronts

The fronts will have 30 mm wide facings that are cut-on and folded over. The left front will have six buttonholes and the right front will have six buttons. Each front will have a patch pocket with a flap. The inner edges of the facings will have been cut with selvedge or will have been acceptably serged; they will not be stitched to the fronts. The sides and the hem will be straight.

Breast Pockets

Each front will have a patch type breast pocket with blunted corners and a 30 mm wide box pleat in the centre (see diagram fig 1). The top of the pocket will have a hem of finished width 15 mm, and the edges of the pocket will have been turned in 5 mm and stitched down 2 mm from the turned-in edge. Each end of the pocket mouth will be secured, over the full width of the hem, with a box tack. On shirts of collar size up to and including 39cm the finished pocket will be 130 mm wide and 140 mm deep; on larger sizes these dimensions will be 140 mm and 150 mm respectively.

Pocket Flaps

The flaps will be shaped flaps lined with self-material, interlined with woven interlining and stitched 6 mm from the turned edges. The finished depth of each flap will be 40 mm at the sides, 60 mm in the centre, and the flap will have a vertical buttonhole in the centre. The flaps will be so positioned that the flap buttonholes are level with the second buttonhole in the left front and there will be a 10 mm wide gap between the top of each pocket and the stitching down of its flap.

Back

The back will have a double yoke of finished depth 70 mm at the centre of the back and 70 mm at the shoulders. The hem will be straight and the sides will be straight.

Collar

The collar shall be a sports type glad neck collar interlined with interlining and edge stitched.

Buttons

Buttons will be securely sewn to positions corresponding to those of the buttonholes. The buttons on the right front will be sewn 15 mm from the front edge. Each button will be secured with the holes aligned with the relevant buttonhole.

Hem

The hem at the bottom of the shirt will have a finished width of 6 mm. The hem will be turned in and stitched down 2 mm from the turned-in edge.



Fig. 1 - Front

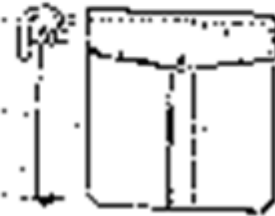

Fig. 2 - Pocket and flap detail

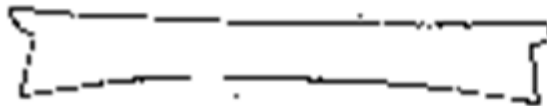

Fig. 3



Fig. 4



Fig. 5 - Sleeve cuff detail

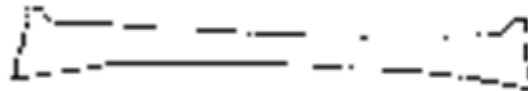

Fig. 6

FIG 1

Shirt:

With 30 mm placket front button.

Semi stiffed raised collar with plastic bones, edge stitched.

Pockets:

Two (2) pleated breast pockets. Blunted bottom corners. Scalloped flaps with buttons.

Pocket size:

30 mm wide centre vertical box pleat. 135 mm wide x 150 mm deep. 10 mm gap between top of pocket and the stitching of the flap.

Sleeves:

The shirt shall have long sleeves with fused gauntlet cuffs with curved points to button and shall accommodate cuff links.

Permanent Crease:

Permanent creases shall be stitched as follows:

- A) Down both front panels from shoulder to hem, to pass behind breast pockets, on a centre line through the box pleat of both pockets.
- B) Back from yoke to hem, 7 cm in from sleeve seams measured in on line of yoke.

Shirt hem :

Shirt tails (not square cut) to be hemmed not overlocked.

Buttons

11,5 mm transparent pearl buttons with two spare buttons fixed to the inside bottom hem.

Collar size:

Shirts with collar sizes from 28 cm to 54 cm is required.

Provision to be made for epaulettes.

MATERIAL SPECIFICATION:

Composition:

65 % polyester 35 % cotton 112 grams per square metre. To conform to S.A.B.S.

Colour:

Optical white

Size S / 37	4
Size M / 39	13
Size L / 42	18
Size XL / 46	5
Size 2XL / 48	2

ITEM 2. BLACK TROUSER

Material

Shall be plain weave – 55% Polyester/45% new wool.

Colour

Black

Trouser Design

The trousers shall have the following features:

Plain bottom single pleated front design. Rubber lined waist band, 35 mm wide.

The loops shall neatly fit a 60 mm wide belt and will be securely bar-tacked 5 mm from the top edge of the waistband and at the bottom.

Eight (8) belt loops 10 mm wide x 65 mm long (between tacks). Inter locking zip fly.

Side pockets shall have vertical double-jetted openings. Hip pocket position centrally on right front.

Permanent creases to commence in line with the bottom of the fly down the front of the trousers leg to hem and the back from belt the seat to hem. Plain finished trouser bottoms.

Edges bluffed or stitched.

Size 30	2
Size 32	10
Size 34	14
Size 36	9
Size 38	7
Size 42	3
Size 40	2
Size 44	2

ITEM 3. BLACK POLYESTER/WOOL LADIES SKIRT

Style

Plain front with two darts back and front.

Fully lined.

Box pleat at the back.

Waistband with belt loops.

Slide fastener closure.

Plain hem.

Fully lined.

Colour

Black

Front

Back

Skirt Openings

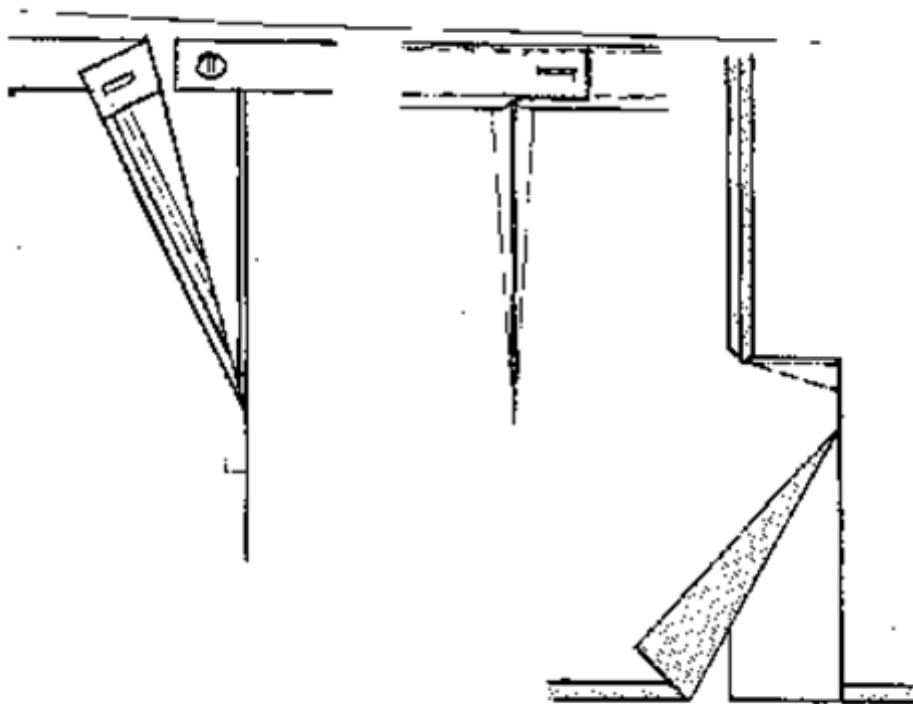

FIG 2

Back Opening View
From Outside

Back Opening View
From Inside

Back Pleat

Materials-general

55% Polyester/45% new wool.

FUNCTIONAL GROUP Apparel



FIG 3

Wash @ 40° c
Cool Iron 120° c
Do Not Bleach
Tumble Dry
Line Dry

Component materials

Interlining

Fusible non-woven interlining.
Suitable for use in garments which may be washed.

Button

Two-hole plastics.
 Full impregnated.
 Dope- dyed.
 Polyester.
 Nominal diameter 15mm.
 Colour Black

Tape

An acceptable tape of nominal width 6mm.

Sizes

Skirt measurements

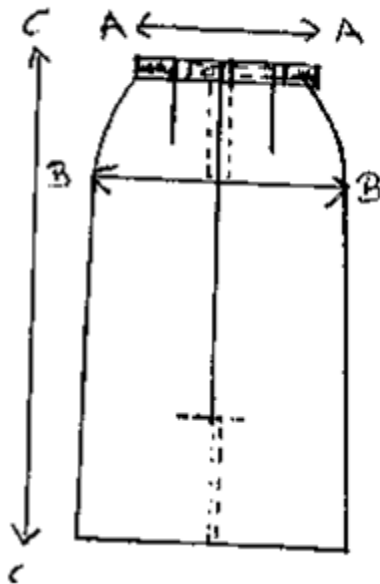

FIG 4

Measuring Point		Description
A - A	Waist Circumference	Measure across the top edge of the waistband and multiply by two.
B - B	Hip Circumference	Measure across the width of the garment, at hip level (widest point), and multiply by two.
C - C	Outside Length	Measure from the top edge of the garment to the bottom edge of the garment leg. Minimum knee height Maximum Mid calf

Front

One piece.
 Two waist darts.
 Two inner darts with finished length of 90mm.
 Two outer darts with finished length of 70mm.

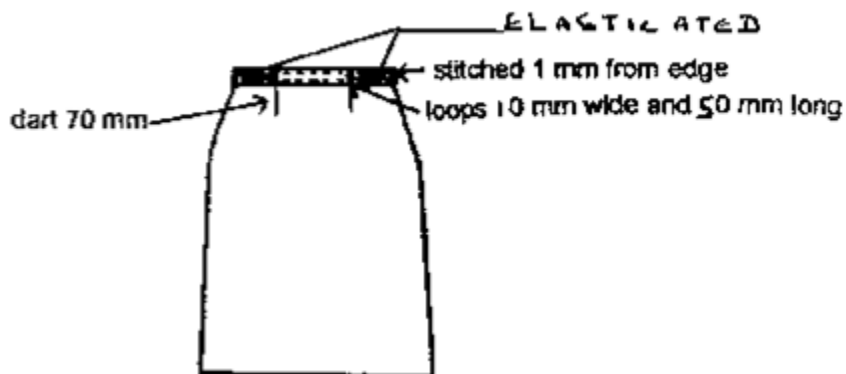

FIG 5
Back

Two panels with one waist darts each.
 One inner dart with finished length of 12cm.
 One outer dart with finished length of 75mm.
 Slide fastener.
 Overlap pleat with finished length of a 10cm above the bend of the knee to the bottom edge of the skirt.
 Top of pleat shall be stitched across the full width of the pleat.

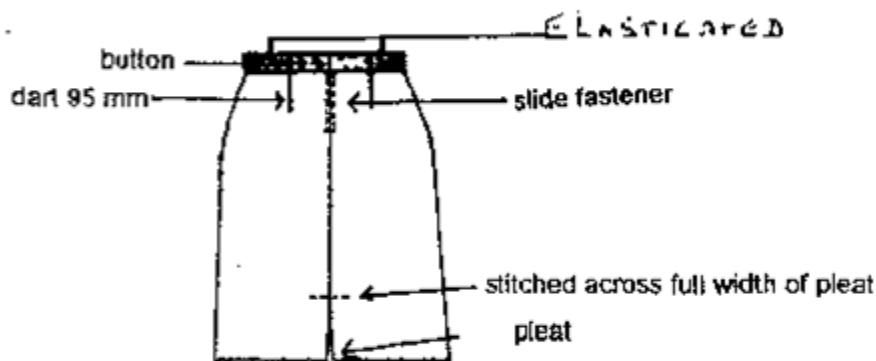

FIG 6
Waistband

Folded outer material interlined with lining and a finished width of 40mm.
 Right end shall have an extension of finished length 40mm.
 Top-stitched all round, 2 mm from the edge.
 Both sides of the waistband to be elasticated.

Belt loops, Belt and Belt Buckle

Six loops in total: One loop to be placed close to either side of the of the zip closure centered at the back of the skirt.

Width 10 mm and length 50mm.

Top stitched 1mm from the free edges.

Stitched into the waistband seam.

Centered over the inner darts at front and side seams .

Stitched down 10mm below waistband, turned up and the edge turned in 10mm and bar tacked 1mm from the top edge of waistband.

Matching belt and buckle.

Hem

Turned up.

Finished width of 35mm.

Skirt lining

Same As outer skirt leaving dart as pleats.

Opening at bottom and top of back seam that correspond to that of slide fastener and the pleat.

Opening of lining shall be stitched 10mm from edge.

Lining shall be 30mm shorter than the skirt.

Bottom shall be hammed.

colour: Black.

Hanger loops

An acceptable tape.

Finished length of 10cm.

Secured with the waistband to skirt seam.

In inside at each side seam.

Buttonhole

One buttonhole.

Neatly barred and gimped.

Length of 18mm.

Centered and 10mm from the edge in the left side of the waistband.

Button

One button.

Securely sewn to the waistband extension.

Corresponding to the buttonhole.

One spare button on the inside of the extension.

Number of stitches

The number of stitches shall be As follows:

Seaming : 40 ± 4 per 10cm

Overlocking stitching : 40 ± 4 per 10cm

Buttonhole : 20 ± 1 per 1cm

Button : 16 ± 1 per button

Packing, care-labelling and marking

Packing

Each garment shall be:

Delivered in a commercially dry condition.

So packed that it will not damage in transit or in storage.

Neatly folded and individually packed in a plastic envelope of suitable size and shape.

Care - labelling

Each garment to have a woven or printed label that is permanently secured and that provides correct and appropriate care instruction.

All care-labels and their markings to be such: that they outlast the garments.

Marking

Each garment shall have a woven fabric label sewn to the inside of the waistband (back).

The label shall provide the following information in legible and indelible block letters of height at least 3mm:

The manufacturer's name or trade mark or both.

The size designation.

The year of manufacture.

Plastic envelopes

Each envelope shall have a sticker-type label clearly marked with the following information:

The designation, i.e."ladies "skirt.

The size designation.

Size 32	6
Size 38	2
Size 40	4
Size 42	2
Size 44	4
Size 46	2

ITEM 4. SHOES BLACK - PARABELLUM

Parabellum shoes:

The shoes shall be constructed of genuine leather uppers with lace.

The shoes shall feature rubber soles.

The soles shall be stitched onto the uppers.

The colour of the shoes shall be black.

Sizes: as per table below

size 5	3
size 6	3
size 7	11
size 8	13
size 9	4
size 10	1
size 11	5
size 12	1

ITEM 5: ELASTIC HALF BOOT

The boot shall be fitted with a toe and shin protection.

The sole shall be constructed of rubber and shall offer excellent chemical resistance and be Non-slip. The boot shall feature a steel toe tip and heel bumper.

The boot shall be a maximum of 250 mm high.

Anti-bacterial lining and sock

Full grain flame/heat-resistant and puncture-resistant leather shall be used for the uppers. The boot shall have excellent water repellent properties.

The boot shall feature a split leather padded collar, leather tongue and shall be lined.

The heel of the boot shall be fitted with a stabilizer.

The boot shall be fitted with a shock absorbing mid-sole.

The boot shall create a watertight seal where the rubber outsole joins the leather upper.

The boot manufacturer shall give a written warrantee that the sole shall not come loose from the uppers with exposure to heat and water.

size 5	1
size 6	3
size 7	10
size 8	14
size 9	5
size 10	2
size 11	4
size 12	1

ITEM 6: WHITE SHORT SLEEVE SHIRT

Fronts see Fig 1

The fronts will have 30 mm wide facings that are cut-on and folded over. The left front will have six buttonholes and the right front will have six buttons. Larger sizes to have eight button holes. Each front will have a patch pocket with a flap. The inner edges of the facings will have been cut with selvedge or will have been acceptably serged; they will not be stitched to the fronts. The sides and the hem will be straight.

Breast Pockets

Each front will have a patch type breast pocket with blunted corners and a 20 mm wide box pleat in the centre. The top of the pocket will have a hem of finished width 15 mm and the edges of the pocket will have been turned in 5 mm and stitched down 2 mm from the turned-in edge. Each end of the pocket mouth will be secured, over the full width of the hem, with a box tack. On shirts of collar size up to and including 39 cm the finished pocket will be 130 mm wide and 140 mm deep; on larger sizes these dimensions will be 140 mm and 150 mm respectively.

Pocket Flaps

The flaps will be shaped flaps lined with self-material, interlined with woven interlining and stitched 6 mm from the turned edges. The finished depth of each flap will be 40 mm at the sides, 60 mm in the center, and the flap will have a vertical buttonhole in the centre. The flaps will be so positioned that the flap buttonholes are level with the second buttonhole in the left front and there will be a 10 mm wide gap between the top of each pocket and the stitching down of its flap.

Back

The back will have a double yoke of finished depth 70 mm at the centre of the back and 70 mm at the shoulders. The hem will be straight and the sides will be straight.

Collar

The collar shall be a sports type glad neck collar interlined with interlining and edge stitched.

Shoulders

Provision to be made for epaulettes.

Buttons

There will be buttons securely sewn to positions corresponding to those of the buttonholes. The buttons on the right front will be sewn 15 mm from the front edge. Each button will be secured with the holes aligned with the relevant buttonhole.

Hem

The hem at the bottom of the shirt will have a finished width of 6 mm. The hem will be turned in and stitched down 2 mm from the turned-in edge. Two spare buttons will be secured to the inside, bottom hem.

Composition

65%polyester/35%cotton

Creases

Permanent creases shall be stitched as follows:

Down both front panels from shoulder to hem, to pass behind breast pockets, on a centre line through the box pleat of both pockets.

Back from yoke to hem, 7 cm in from sleeve seams measured in on-line of yoke.

Size S	5
Size M	14
Size L	10
Size XL	6
Size 2XL	3

ITEM 7. CHARCOAL GREY T SHIRT WITH LOGO

Material:

100% super carded cotton single jersey 160g

Colour:

The colour shall be Charcoal Grey as per sample.

Badge:

The badge as specified shall be embroidered directly onto the left breast of each shirt. The embroidery shall be of a high standard.

Screen Printing:

Require embroidery on back as specified: as per sample.

RAY NKONYENI, FIRE RESCUE & DISASTER

The colour of the screen printing shall be **SILVER**.

The Maltese cross logo as per sample to be positioned on left chest side.

Size S	10
Size M	33
Size L	32
Size XL	25
Size 2XL	10

ITEM 8. BLACK BIOGARD SOCKS

Style:

¼ hose (anklets) socks are required.
The socks shall feature a double over elasticated top.
The toe closure shall be overlapped.

Colour:

The socks shall be black as specified.

The material shall be cotton. The material shall have a thickness of not less than 2,5 mm.
The socks shall have cushion soles. Bio-guard type socks are required.

Black Bio guard Socks	200
-----------------------	-----

ITEM 9 . NAVY COMBAT TROUSERS

Fly

The fly will be a zip fly with a heavy-duty Nylon.

Button-catch.

The button-catch will be cut on and lined with outer material, and will have a finished width of 20mm, carried through to the crutch, and stitches down onto the front crutch seam.

Waistband

The waistband will be cut on and will be lined with outer material that is so shaped as to fit the trouser top. The bottom edge of the waistband lining will be over locked and stitched through the trouser 75 mm from the top edge of the waistband. There will be two buttonholes at each end of the trouser front. The former buttonhole will be positioned.

120 mm, and the latter 90 mm, from the outside edge of the fly or button-catch seam. All buttonholes will be so positioned that the top of each buttonhole is 25 mm below the top edge of the waistband.

A length of tape that is long enough (before adjustment) to provide a protrusion of 200 mm at each end will have been threaded through the buttonholes and secured in positioned by stitching through the label, waistband lining, tape and trousers near the centre back seam.

Composition:

50/50 polyester field dress

Belt loops

Each pair of trousers will have five belt loops for trousers with a waist measurement not exceeding 81 cm, and seven belt loops on larger sizes.

The loops will be 20 mm wide, of double-folded outer material, boxed, turned, single stitches and secured at the following positions:

One of on each front, 100 mm from the front edge of the fly, and 140 mm from the front edge of the button-catch (As relevant), one at each side seam (stitched to the back panels), and one just off the centre back seam.

When seven loops are required, an additional loop will be secured at the centre of each back panel.

The loops shall neatly fit a 60 mm wide belt and will be securely bar-tacked 5 mm from the top edge of the waistband and at the bottom.

Pockets

All pocket bags will be of outer material, will be double-stitched, and both upper ends of the bags of the side pocket and one upper end of the hip pocket bag will be carried under the waistband lining. Each end of the mouth of each pocket will be securely finished off with a bar tack that, for the hip pocket, is inserted vertically. The pockets will be as follows:

Side pockets: Side pockets will have vertical mouth openings. On trousers with a waist measurement not exceeding 87 cm, the length of the mouth opening will be 170 mm and the pocket bag will have a finished width of 140 mm and a finished depth (below the lower bar tack) of 150 mm. On larger sizes these dimensions will be 170 mm, 160 mm and 150 mm respectively. On all trousers the top bar tack in the pocket mouth will be positioned 110 mm below the top edge of the waistband.

Hip pocket: The pocket will be a half-jetted pocket with a concealed button closure. On trousers with a waist measurement not exceeding 87 cm, the finished pocket bag will have a width of 160 mm and a mouth opening of length 130 mm. On larger sizes these dimensions will be 180 mm, 180 mm and 150 mm respectively. On all trousers the top of the pocket opening will be positioned 110 mm below the top edge of the waistband.

Field-dressing pocket: The pocket will be a patch pocket with square corners and will have a vertical 25 mm deep knife pleat in the centre. The mouth of the pocket will have a hem of finished depth 25 mm and will fasten with a Velcro patch of 15 mm x 15 mm. The finished pocket will have a width of 120 mm and a depth of 150 mm (outside dimension), and will be centrally positioned on the right front with its top edge in line with the top tack of the side pocket mouth, and the back edge 30 mm from the side seam. The edges of the pocket will be stitched with one row of stitches 2 mm from the turned-in edges.

Bottoms

The bottoms will be plain, folded in and stitched down. The fold-in will be 25 mm deep when finished.

Buttonholes and Eyelets

There will be one in each hip pocket and two in each thigh pocket flap. In addition, there will be two-shirt type buttonholes in each end of the waist tunnel and two at the centre and so positioned that the edge of the eye is at least 5 mm from the relevant turned-in edge. Shirt-type buttonholes will have a bar at each end. Eyelets will be round and will be machine made.

Buttons

There will be five or six buttons as relevant on the button-catch, two on each thigh pocket and one on the hip pocket. All buttons will be secured at positions that correspond to those of the relevant buttonholes. In addition, each pair of trousers will have two spare buttons secured to a front end of the waistband lining.

Creases

The front and back creases will be edge-stitched 2 mm from the edge, in each case, starting at a line level with the base of the field-dress pocket, and finishing at the top of the bottom hem.

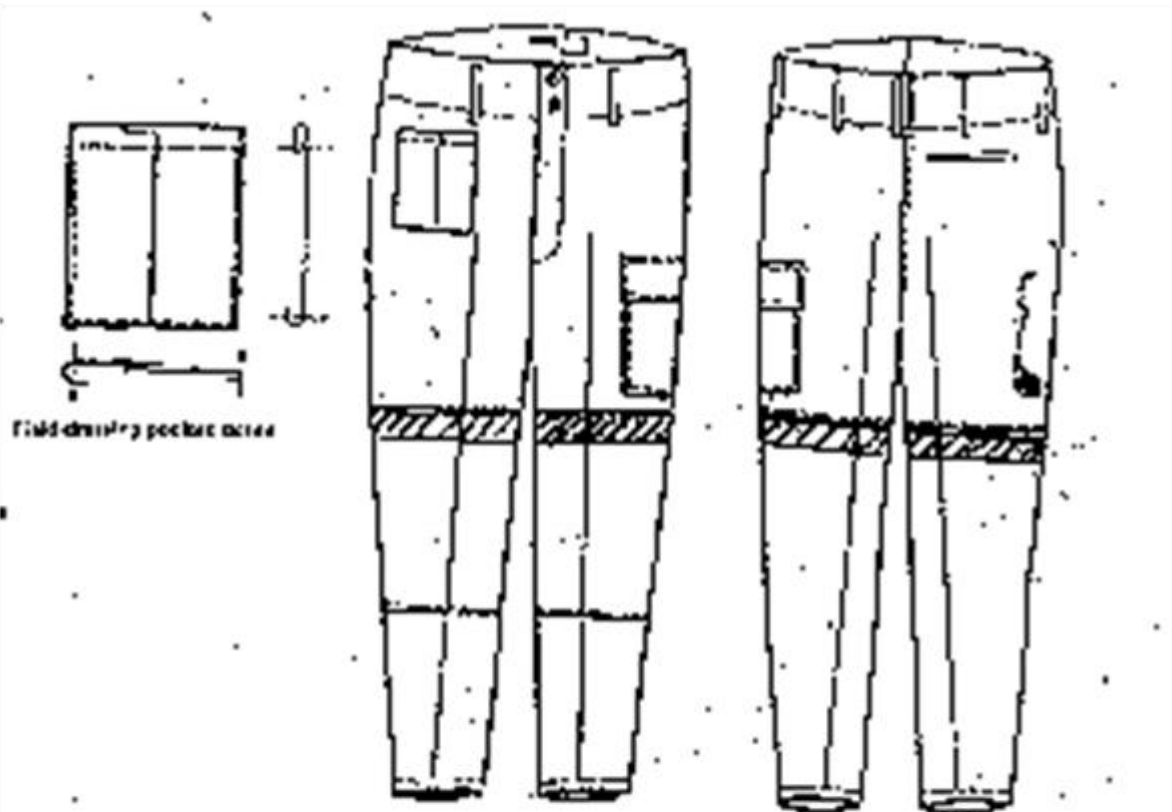

Fig. 1 - Front

Fig. 2 - Back

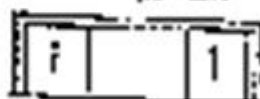
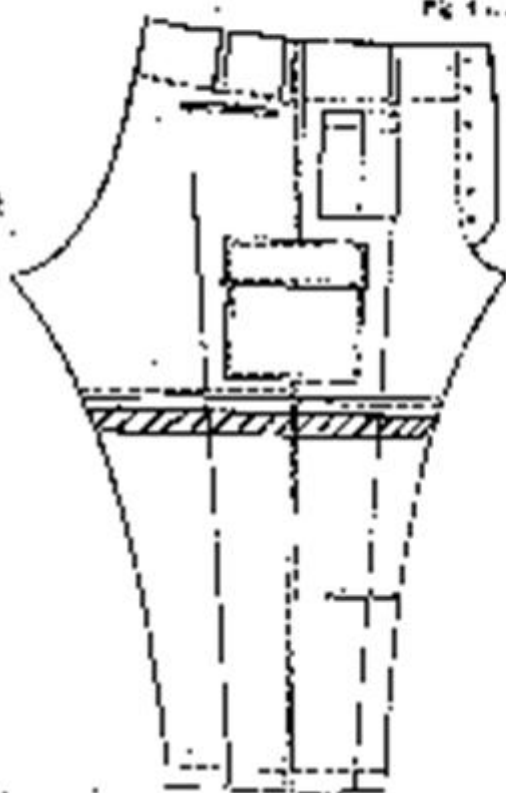

Fig. 3 - Detail

FIG 7

Size 30	20
Size 32	40
Size 34	80
Size 36	40
Size 38	30
Size 40	7
Size 42	12
Size 44	10

ITEM 10 . BLACK ANORAKS

The style of the jacket shall be an all-weather type of jacket,
The style of the jacket shall be acceptable to be worn as uniform.
The length of the jacket to be upper thigh length

The body and sleeves shall be quilted.

The cuffs and waistband shall be elasticated, and to be attached to the inner lining.
A zip front with a storm flap with press-stud closing is required. The zipper shall be a heavy-duty nylon zip. The closing shall feature at least 5 press studs with a 10 mm diameter. The colour of the studs shall be silver.

Two patch type breast pockets with press-stud closing flaps are required. The corners shall be blunted, the top of the pocket will have a hem of finished width 15 mm, and the edges of the pocket will have been turned in 5 mm and stitched down 2 mm from the turned-in edge. Each end of the pocket mouth will be secured, over the full width of the hem, with a box tack.

On jackets of collar size up to and including 39 cm the finished collar will be 130 mm wide and 140 mm deep; on larger sizes these dimensions will be 140 mm and 150 mm respectively.
Two slanted welted side pockets are required. The length of the mouth opening will be 170 mm.
One inside breast pocket with press-stud closing flap is required.
Require hood to be in zipped section of collar.
Require badge as per sample on left side of chest.

Embroidery shall be as specified.
RAY NKONYENI, FIRE RESCUE & DISASTER

The colour of the screen printing shall be **SILVER**.

Size S	3
Size M	10
Size L	21
Size XL	11
Size XXL	2

ITEM 11. BLACK WEBBING BELTS WITH FIRE LOGOS

The belt shall be constructed of 56 mm wide acrylic webbing.

Composition: polyester

The colour of the webbing shall be across the length of the webbing: Colour to be plain BLACK.

The belts shall be supplied complete with a die stamped, oval fire buckle and hooking pin. SUPPLIED LOGO will be stamped into the buckle banner.

Size S	5
Size M	5
Size L	5
Size XL	5

ITEM 12 . EPAULETTES

Rank markings are to be printed on black fabric material.

Printing to be silver.

Chief Fire Officer	wreath/impellers
Station Commander	2 impellers x 4units
Leading Fire Fighter	2 stripes x 6units
Fireman	cross axes x 80 units
Controllers	plain

TOTAL	100 units
-------	----------------------

ITEM 13 . FLASHERS

Maltese cross with RNM logo and black base as per Sample

TOTAL	100 units
-------	----------------------

ITEM 14. NAVY SHORT SLEEVE COMBAT SHIRTS

Fronts see Fig 1

The fronts will have 30 mm wide facings that are cut-on and folded over. The left front will have six buttonholes and the right front will have six buttons. Larger sizes to have eight button holes. Each front will have a patch pocket with a flap. The inner edges of the facings will have been cut with selvedge or will have been acceptably serged; they will not be stitched to the fronts. The sides and the hem will be straight.

Breast Pockets

Each front will have a patch type breast pocket with blunted corners and a 20 mm wide box pleat in the centre. The top of the pocket will have a hem of finished width 15 mm and the edges of the pocket will have been turned in 5 mm and stitched down 2 mm from the turned-in edge. Each end of the pocket mouth will be secured, over the full width of the hem, with a box tack. On shirts of collar size up to and including 39 cm the finished pocket will be 130 mm wide and 140 mm deep; on larger sizes these dimensions will be 140 mm and 150 mm respectively.

Pocket Flaps

The flaps will be shaped flaps lined with self-material, interlined with woven interlining and stitched 6 mm from the turned edges. The finished depth of each flap will be 40 mm at the sides, 60 mm in the centre, and the flap will have a vertical buttonhole in the centre. The flaps will be so positioned that the flap buttonholes are level with the second buttonhole in the left front and there will be a 10 mm wide gap between the top of each pocket and the stitching down of its flap.

Back

The back will have a double yoke of finished depth 70 mm at the centre of the back and 70 mm at the shoulders. The hem will be straight and the sides will be straight.

Collar

The collar shall be a sports type glad neck collar interlined with interlining and edge stitched.

Shoulders

Provision to be made for epaulettes.

Buttons

There will be buttons securely sewn to positions corresponding to those of the buttonholes. The buttons on the right front will be sewn 15 mm from the front edge. Each button will be secured with the holes aligned with the relevant buttonhole.

Hem

The hem at the bottom of the shirt will have a finished width of 6 mm. The hem will be turned in and stitched down 2 mm from the turned-in edge. Two spare buttons will be secured to the inside, bottom hem.

Creases

Permanent creases shall be stitched as follows:

Down both front panels from shoulder to hem, to pass behind breast pockets, on a centre line through the box pleat of both pockets.

Back from yoke to hem, 7 cm in from sleeve seams measured in on line of yoke.

Composition:

50/50 polyester cotton field dress

Logos:

RNM embroidered positioned on left side
RAY NKONYENI, FIRE RESCUE & DISASTER

Size S	8
Size M	60
Size L	60
Size XL	24
Size 2XL	4

ITEM 15. BASEBALL CAPS

Heavy Acrylic (100%)

Fade Resistant

6 Panel Structured

Embroidered Eyelets

Pre-Curved Peak

Self-Covered Velcro Strap
4 Row Stitched Sweatband
Branding Area: 120mm x 60mm
Embroidery Maltese cross
Colour Navy with red piping.
RNM fire logo embroidered on front.

ITEM 16. STEP OUT GLOVES

White 100% cotton gloves
Elasticated cuffs.
Size S, M, L and XL

ITEM 17. KNITTED BEANIES WITH LOGO

64g Acrylic Knitted
Stretch-Fit
Fold Up Band
Branding Area: 40mm x 130mm
RNM fire logo embroidered on front.
Colour Navy

ITEM 18. RAINCOATS WITH LOGO

Navy blue with logo
180gsm polyester fabric coated with poly Urethane conforming to EN471 and SANS 50471
25 wash 50 mm reflective red tape
Jacket to include mesh lining and hood in the collar.
Seams to fully sealed.
Garment to be 100% waterproof.

Size S	3
Size M	10
Size L	21
Size XL	11
Size XXL	2

ITEM 19. METALETTE ID SHIELD

Integrated Badge to be manufactured from Metalette and plated.
Name bar to be made from ABS and epoxy coated.
Shield and name badge to be integrated by melt back system. This serves to prevent dislodgement and for security reasons cannot be removed or reassembled without destroying the shield.
Between the base and badges to be a material section, this to be synthetic royal blue material with an indented outer border.
Attachment method to be via safety pin type.
RNM fire logo on shield.

ITEM 20. BUNNY JACKET WITH LOGO

Bunny Jacket
50/50 poly cotton combat fabric
Shoulder straps for epaulettes

Double collar, that zips up to chin.
 Two hand warmer pockets
 Two top pockets with inverted pleats and envelope flap.
 Concealed zip front with inner flap
 Press stud closure leading to double collar construction.
 Lined and padded throughout
 Elasticated cuffs and waist
 Press studs s-spring type.
 Zip spiral nylon Logos:
 Colour Navy
 RNM embroidered positioned on left side.
 RAY NKONYENI, FIRE RESCUE & DISASTER

Size S	3
Size M	10
Size L	21
Size XL	11
Size XXL	2

ITEM 21. COLLAR TYPE GOLFER TEE SHIRTS WITH LOGO

Material:
 100% super carded cotton single jersey 170g
 Colour:
 The colour shall be navy.
 Two ridge collars
 Red piping on Navy collar
 Double needle finish on sleeves and hem
 Three button plackets
 supplied with a loose pocket.
 Self-fabric neck tape on collar seam

Badge:
 The badge as specified shall be embroidered directly onto the left breast of each shirt. The embroidery shall be of a high standard.

The Maltese cross logo as per sample to be positioned on left chest side.

Size S	10
Size M	33
Size L	32
Size XL	25
Size 2XL	10

ITEM 22. PEAK CAPS

Officers cap with a high crown rolled construction laminated fabric on foam.
 Fully lined with polyester and velveteen sweat band.
 Ventilation eyelets in the bevel.
 Oak leaf band
 Leather chin strap
 Plastic buttons
 Red piping.
 Shiny Peak, Cloth covered peak.

Ranked or Plain.

ITEM 23. TIE

146cm length
9cm width on front point
100% polyester crepe
100% washable
Lurex Embroidery when required.
Black with silver embroidery [cross axes]

ITEM 24. LANYARD

Single plain lanyard
Polyester outer
Cotton inner
Standard 7mm
Red in Colour

SUPPLIER'S SIGNATURE

DATE

- Required by:
- At:
- Brand and Model
- Country of Origin
- Does offer comply with specification? *YES/NO
- If not to specification, indicate deviation(s)
- Period required for delivery
- *Delivery: Firm/not firm
- Delivery basis (all delivery costs must be included in the bid price)

Note: All delivery costs must be included in the bid price, for delivery at the prescribed destination.

*** “ all applicable taxes “ includes value added tax, pay as you earn(PAYE), income tax , unemployment insurance fund (UIF) and skills development levies.

***Delete if not applicable**

DECLARATION OF INTEREST

1. No bid will be accepted from persons in the service of the state¹.
2. Any person, having a kinship with persons in the service of the state, including a blood relationship, may make an offer or offers in terms of this invitation to bid. In view of possible allegations of favouritism, should the resulting bid, or part thereof, be awarded to persons connected with or related to persons in service of the state, it is required that the bidder or their authorised representative declare their position in relation to the evaluating/adjudicating authority.

3 In order to give effect to the above, the following questionnaire must be completed and submitted with the bid.

3.1 Full Name of bidder or his or her representative:.....

3.2 Identity Number:

3.3 Position occupied in the Company (director, trustee, shareholder²):.....

3.4 Company Registration Number:

3.5 Tax Reference Number:.....

3.6 VAT Registration Number:

3.7 The names of all directors / trustees / shareholders members, their individual identity numbers and state employee numbers must be indicated in paragraph 4 below.

3.8 Are you presently in the service of the state? **YES / NO**

3.8.1 If yes, furnish particulars.

¹MSCM Regulations: "in the service of the state" means to be –

- (a) a member of –
 - (i) any municipal council;
 - (ii) any provincial legislature; or
 - (iii) the national Assembly or the national Council of provinces;
- (b) a member of the board of directors of any municipal entity;
- (c) an official of any municipality or municipal entity;
- (d) an employee of any national or provincial department, national or provincial public entity or constitutional institution within the meaning of the Public Finance Management Act, 1999 (Act No.1 of 1999);
- (e) a member of the accounting authority of any national or provincial public entity; or
- (f) an employee of Parliament or a provincial legislature.

² Shareholder" means a person who owns shares in the company and is actively involved in the management of the company or business and exercises control over the company.

3.9 Have you been in the service of the state for the past twelve months? **YES / NO**

3.9.1 If yes, furnish particulars.....

3.10 Do you have any relationship (family, friend, other) with persons in the service of the state and who may be involved with the evaluation and or adjudication of this bid? **YES / NO**

3.10.1 If yes, furnish particulars.
.....
.....

3.11 Are you, aware of any relationship (family, friend, other) between any other bidder and any persons in the service of the state who may be involved with the evaluation and or adjudication of this bid? **YES / NO**

3.11.1 If yes, furnish particulars
.....
.....

3.12 Are any of the company's directors, trustees, managers, principle shareholders or stakeholders in service of the state? **YES / NO**

3.12.1 If yes, furnish particulars.
.....
.....

3.13 Are any spouse, child or parent of the company's directors trustees, managers, principle shareholders or stakeholders in service of the state? **YES / NO**

3.13.1 If yes, furnish particulars.
.....
.....

3.14 Do you or any of the directors, trustees, managers, principle shareholders, or stakeholders of this company have any interest in any other related companies or business whether or not they are bidding for this contract. **YES / NO**

3.14.1 If yes, furnish particulars:
.....
.....

4. Full details of directors / trustees / members / shareholders.

Full Name	Identity Number	State Employee Number

CERTIFICATION

I, _____ THE UNDERSIGNED CERTIFY THAT THE INFORMATION FURNISHED ON THIS DECLARATION FORM IS CORRECT.

ACCEPT THAT THE COUNCIL MAY ACT AGAINST ME SHOULD THIS DECLARATION PROVE TO BE FALSE.

.....
Signature

.....
Date

.....
Capacity

.....
Name of Bidder

PREFERENCE POINTS CLAIM FORM IN TERMS OF THE PREFERENTIAL PROCUREMENT REGULATIONS 2022

This preference form must form part of all tenders invited. It contains general information and serves as a claim form for preference points for specific goals.

NB: BEFORE COMPLETING THIS FORM, TENDERERS MUST STUDY THE GENERAL CONDITIONS, DEFINITIONS AND DIRECTIVES APPLICABLE IN RESPECT OF THE TENDER AND PREFERENTIAL PROCUREMENT REGULATIONS, 2022

1 GENERAL CONDITIONS

- 1.1 The following preference point systems are applicable to invitations to tender:
- the 80/20 system for requirements with a Rand value of up to R50 000 000 (all applicable taxes included); and
 - the 90/10 system for requirements with a Rand value above R50 000 000 (all applicable taxes included).
- 1.2 **To be completed by the organ of state**
(delete whichever is not applicable for this tender).
- a) The applicable preference point system for this tender is the 80/20 preference point system.
- 1.3 Points for this tender (even in the case of a tender for income-generating contracts) shall be awarded for:
- (a) Price; and
 - (b) Specific Goals.
- 1.4 **To be completed by the organ of state:**
 The maximum points for this tender are allocated as follows:
- 1.5 Failure on the part of a tenderer to submit proof or documentation required in terms of this tender to claim points for specific goals with the tender, will be interpreted to mean that preference points for specific goals are not claimed.
- 1.6 The organ of state reserves the right to require of a tenderer, either before a tender is adjudicated or at any time subsequently, to substantiate any claim in regard to preferences, in any manner required by the organ of state.

2. DEFINITIONS

- (a) **“tender”** means a written offer in the form determined by an organ of state in response to an invitation to provide goods or services through price quotations, competitive tendering process or any other method envisaged in legislation;
- (b) **“price”** means an amount of money tendered for goods or services, and includes all applicable taxes less all unconditional discounts;
- (c) **“rand value”** means the total estimated value of a contract in Rand, calculated at the time of bid invitation, and includes all applicable taxes;
- (d) **“tender for income-generating contracts”** means a written offer in the form

determined by an organ of state in response to an invitation for the origination of income-generating contracts through any method envisaged in legislation that will result in a legal agreement between the organ of state and a third party that produces revenue for the organ of state, and includes, but is not limited to, leasing and disposal of assets and concession contracts, excluding direct sales and disposal of assets through public auctions; and

- (e) “**the Act**” means the Preferential Procurement Policy Framework Act, 2000 (Act No. 5 of 2000).

3. FORMULAE FOR PROCUREMENT OF GOODS AND SERVICES

3.1. POINTS AWARDED FOR PRICE

3.1.1 THE 80/20 OR 90/10 PREFERENCE POINT SYSTEMS

A maximum of 80 or 90 points is allocated for price on the following basis:

$$Ps = 80 \left(1 - \frac{Pt - P_{min}}{P_{min}} \right) \text{ or } Ps = 90 \left(1 - \frac{Pt - P_{min}}{P_{min}} \right)$$

Where

Ps = Points scored for price of tender under consideration

Pt = Price of tender under consideration

Pmin = Price of lowest acceptable tender.

3.2. FORMULAE FOR DISPOSAL OR LEASING OF STATE ASSETS AND INCOME GENERATING PROCUREMENT

3.2.1. POINTS AWARDED FOR PRICE

A maximum of 80 or 90 points is allocated for price on the following basis:

$$Ps = 80 \left(1 + \frac{Pt - P_{max}}{P_{max}} \right) \text{ or } Ps = 90 \left(1 + \frac{Pt - P_{max}}{P_{max}} \right)$$

Where

Ps = Points scored for price of tender under consideration

Pt = Price of tender under consideration

Pmax = Price of highest acceptable tender

4. POINTS AWARDED FOR SPECIFIC GOALS

- 4.1. In terms of Regulation 4(2); 5(2); 6(2) and 7(2) of the Preferential Procurement Regulations,

preference points must be awarded for specific goals stated in the tender. For the purposes of this tender the tenderer will be allocated points based on the goals stated in table 1 below as may be supported by proof/ documentation stated in the conditions of this tender:

4.2. In cases where organs of state intend to use Regulation 3(2) of the Regulations, which states that, if it is unclear whether the 80/20 or 90/10 preference point system applies, an organ of state must, in the tender documents, stipulate in the case of—

(a) an invitation for tender for income-generating contracts, that either the 80/20 or 90/10 preference point system will apply and that the highest acceptable tender will be used to determine the applicable preference point system; or

(b) any other invitation for tender, that either the 80/20 or 90/10 preference point system will apply and that the lowest acceptable tender will be used to determine the applicable preference point system,

then the organ of state must indicate the points allocated for specific goals for both the 90/10 and 80/20 preference point system.

Table 1: Specific goals for the tender and points claimed are indicated per the table below.

The specific goals allocated points in terms of this tender	Number of points allocated (80/20 system) (To be completed by the organ of state)	Number of points claimed (80/20 system) (To be completed by the tenderer)
51% or more black owned company	20	
Ownership of company is not 51% or more black owned	10	

DECLARATION WITH REGARD TO COMPANY/FIRM

4.3. Name of company/firm.....

4.4. Company registration number:

4.5. TYPE OF COMPANY/ FIRM

Partnership/Joint Venture / Consortium

- One-person business/sole propriety
- Close corporation
- Public Company
- Personal Liability Company
- (Pty) Limited
- Non-Profit Company
- State Owned Company

[TICK APPLICABLE BOX]

4.6. I, the undersigned, who is duly authorised to do so on behalf of the company/firm, certify that the points claimed, based on the specific goals as advised in the tender, qualifies the company/ firm for the preference(s) shown and I acknowledge that:

- i) The information furnished is true and correct;
- ii) The preference points claimed are in accordance with the General Conditions as indicated in paragraph 1 of this form;
- iii) In the event of a contract being awarded as a result of points claimed as shown in paragraphs 1.4 and 4.2, the contractor may be required to furnish documentary proof to the satisfaction of the organ of state that the claims are correct;
- iv) If the specific goals have been claimed or obtained on a fraudulent basis or any of the conditions of contract have not been fulfilled, the organ of state may, in addition to any other remedy it may have –
 - (a) disqualify the person from the tendering process;
 - (b) recover costs, losses or damages it has incurred or suffered as a result of that person's conduct;
 - (c) cancel the contract and claim any damages which it has suffered as a result of having to make less favourable arrangements due to such cancellation;
 - (d) recommend that the tenderer or contractor, its shareholders and directors, or only the shareholders and directors who acted on a fraudulent basis, be restricted from obtaining business from any organ of state for a period not exceeding 10 years, after the *audi alteram partem* (hear the other side) rule has been applied; and
 - (e) forward the matter for criminal prosecution, if deemed necessary.

..... SIGNATURE(S) OF TENDERER(S)	
SURNAME AND NAME:
DATE:
ADDRESS:

DECLARATION OF BIDDER’S PAST SUPPLY CHAIN MANAGEMENT PRACTICES

- 1 This Municipal Bidding Document must form part of all bids invited.
- 2 It serves as a declaration to be used by municipalities and municipal entities in ensuring that when goods and services are being procured, all reasonable steps are taken to combat the abuse of the supply chain management system.
- 3 The bid of any bidder may be rejected if that bidder, or any of its directors have:
 - a. abused the municipality’s / municipal entity’s supply chain management system or committed any improper conduct in relation to such system;
 - b. been convicted for fraud or corruption during the past five years;
 - c. willfully neglected, reneged on or failed to comply with any government, municipal or other public sector contract during the past five years; or
 - d. been listed in the Register for Bid Defaulters in terms of section 29 of the Prevention and Combating of Corrupt Activities Act (No 12 of 2004).
- 4 **In order to give effect to the above, the following questionnaire must be completed and submitted with the bid.**

Item	Question	Yes	No
4.1	<p>Is the bidder or any of its directors listed on the National Treasury’s Database of Restricted Suppliers as companies or persons prohibited from doing business with the public sector?</p> <p>(Companies or persons who are listed on this Database were informed in writing of this restriction by the Accounting Officer/Authority of the institution that imposed the restriction after the <i>audi alteram partem</i> rule was applied).</p> <p>The Database of Restricted Suppliers now resides on the National Treasury’s website(www.treasury.gov.za) and can be accessed by clicking on its link at the bottom of the home page.</p>	<p>Yes</p> <input type="checkbox"/>	<p>No</p> <input type="checkbox"/>
4.1.1	If so, furnish particulars:		
4.2	<p>Is the bidder or any of its directors listed on the Register for Bid Defaulters in terms of section 29 of the Prevention and Combating of Corrupt Activities Act (No 12 of 2004)?</p> <p>The Register for Bid Defaulters can be accessed on the National Treasury’s website (www.treasury.gov.za) by clicking on its link at the bottom of the home page.</p>	<p>Yes</p> <input type="checkbox"/>	<p>No</p> <input type="checkbox"/>
4.2.1	If so, furnish particulars:		

4.3	Was the bidder or any of its directors convicted by a court of law (including a court of law outside the Republic of South Africa) for fraud or corruption during the past five years?	Yes <input type="checkbox"/>	No <input type="checkbox"/>
4.3.1	If so, furnish particulars:		
Item	Question	Yes	No
4.4	Does the bidder or any of its directors owe any municipal rates and taxes or municipal charges to the municipality / municipal entity, or to any other municipality / municipal entity, that is in arrears for more than three months?	Yes <input type="checkbox"/>	No <input type="checkbox"/>
4.4.1	If so, furnish particulars:		
4.5	Was any contract between the bidder and the municipality / municipal entity or any other organ of state terminated during the past five years on account of failure to perform on or comply with the contract?	Yes <input type="checkbox"/>	No <input type="checkbox"/>
4.7.1	If so, furnish particulars:		

CERTIFICATION

I, THE UNDERSIGNED (FULL NAME)

CERTIFY THAT THE INFORMATION FURNISHED ON THIS DECLARATION FORM TRUE AND CORRECT.

I ACCEPT THAT, IN ADDITION TO CANCELLATION OF A CONTRACT, ACTION MAY BE TAKEN AGAINST ME SHOULD THIS DECLARATION PROVE TO BE FALSE.

.....
Signature

.....
Date

.....
Position

.....
Name of Bidder

CERTIFICATE OF INDEPENDENT BID DETERMINATION

1. This Municipal Bidding Document (MBD) must form part of all bids¹ invited.
2. Section 4 (1) (b) (iii) of the Competition Act No. 89 of 1998, as amended, prohibits an agreement between, or concerted practice by, firms, or a decision by an association of firms, if it is between parties in a horizontal relationship and if it involves collusive bidding (or bid rigging).² Collusive bidding is a *pe se* prohibition meaning that it cannot be justified under any grounds.
3. Municipal Supply Regulation 38 (1) prescribes that a supply chain management policy must provide measures for the combating of abuse of the supply chain management system, and must enable the accounting officer, among others, to:
 - (a) take all reasonable steps to prevent such abuse;
 - (b) reject the bid of any bidder if that bidder or any of its directors has abused the supply chain management system of the municipality or municipal entity or has committed any improper conduct in relation to such system; and
 - (c) cancel a contract awarded to a person if the person committed any corrupt or fraudulent act during the bidding process or the execution of the contract.
4. This MBD serves as a certificate of declaration that would be used by institutions to ensure that, when bids are considered, reasonable steps are taken to prevent any form of bid-rigging.
5. In order to give effect to the above, the attached Certificate of Bid Determination (MBD9) must be completed and submitted with the bid:

¹Includes price quotations, advertised competitive bids, limited bids and proposals.

² Bid rigging (or collusive bidding) occurs when businesses, that would otherwise be expected to compete, secretly conspire to raise prices or lower the quality of goods and / or services for purchasers who wish to acquire goods and / or services through a bidding process. Bid rigging is, therefore, an agreement between competitors not to compete.

CERTIFICATE OF INDEPENDENT BID DETERMINATION

I, the undersigned, in submitting the accompanying bid:

_____ (Bid Number and Description)

in response to the invitation for the bid made by:

_____ (Name of Municipality / Municipal Entity)

do hereby make the following statements that I certify to be true and complete in every respect:

I certify, on behalf of: _____ that:
(Name of Bidder)

1. I have read and I understand the contents of this Certificate;
2. I understand that the accompanying bid will be disqualified if this Certificate is found not to be true and complete in every respect;
3. I am authorized by the bidder to sign this Certificate, and to submit the accompanying bid, on behalf of the bidder;
4. Each person whose signature appears on the accompanying bid has been authorized by the bidder to determine the terms of, and to sign, the bid, on behalf of the bidder;
5. For the purposes of this Certificate and the accompanying bid, I understand that the word "competitor" shall include any individual or organization, other than the bidder, whether or not affiliated with the bidder, who:
 - (a) has been requested to submit a bid in response to this bid invitation;
 - (b) could potentially submit a bid in response to this bid invitation, based on their qualifications, abilities or experience; and
 - (c) provides the same goods and services as the bidder and/or is in the same line of business as the bidder.
6. The bidder has arrived at the accompanying bid independently from, and without consultation, communication, agreement or arrangement with any competitor. However communication between partners in a joint venture or consortium³ will not be construed as collusive bidding.
7. In particular, without limiting the generality of paragraphs 6 above, there has been no consultation, communication, agreement or arrangement with any competitor regarding:
 - (a) prices;
 - (b) geographical area where product or service will be rendered (market allocation);
 - (c) methods, factors or formulas used to calculate prices;

- (d) the intention or decision to submit or not to submit, a bid;
 - (e) the submission of a bid which does not meet the specifications and conditions of the bid; or
 - (f) bidding with the intention not to win the bid.
8. In addition, there have been no consultations, communications, agreements or arrangements with any competitor regarding the quality, quantity, specifications and conditions or delivery particulars of the products or services to which this bid invitation relates.
9. The terms of the accompanying bid have not been, and will not be, disclosed by the bidder, directly or indirectly, to any competitor, prior to the date and time of the official bid opening or of the awarding of the contract.
10. I am aware that, in addition and without prejudice to any other remedy provided to combat any restrictive practices related to bids and contracts, bids that are suspicious will be reported to the Competition Commission for investigation and possible imposition of administrative penalties in terms of section 59 of the Competition Act No. 89 of 1998 and or may be reported to the National Prosecuting Authority (NPA) for criminal investigation and or may be restricted from conducting business with the public sector for a period not exceeding ten (10) years in terms of the Prevention and Combating of Corrupt Activities Act No. 12 of 2004 or any other applicable legislation.

SIGNATURE

DATE

POSITION

NAME OF BIDDER

³ Joint venture or Consortium means an association of persons for the purpose of combining their expertise, property, capital, efforts, skill and knowledge in an activity for the execution of a contract.